

# PLASTICADE®

Increase your visibility.

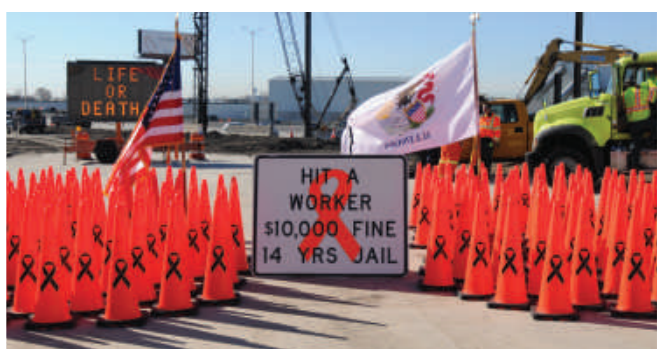

## TRAFFIC SAFETY PRODUCTS





# TABLE OF CONTENTS

- » **BARRICADES, Types I, II, & III**
  - Type I and II Barricades ..... 1,2
  - Safetycade & Verticade ..... 2
  - Barricade Boards ..... 7
  - Type III Barricades ..... 8,9,10
- » **WATER FILLED AIRPORT & ROADWAY BARRICADES**
  - Lo-Pro Airport Barricade ..... 3
  - Water Filled Barricade System ..... 4,5
- » **BARRICADE SYSTEMS - LCD'S & ADA**
  - ADA Pathcade ..... 6
  - Strongwall ..... 7
- » **CONES**
  - Watchtower Stacker Cone ..... 11
  - PVC Traffic Cones ..... 11
- » **CHANNELIZERS**
  - Traffic Drums ..... 12,13
  - Navicade & C42 ..... 14,15
  - Gemstone Vertical Panel ..... 15
  - Watchtower Delineator ..... 16
  - Open Top Delineator ..... 16
  - Watchtower Stacker Cone ..... 11
- » **CROWD CONTROL**
  - ADA Pathcade ..... 6
  - A-Frame Barricades ..... 17
  - Crowdcade Crowd Control Barricades ..... 18,19
- » **PLASTICADE MODULAR GLARE SCREEN** ..... 20,21
- » **STOP/SLOW PADDLES** ..... 22
- » **TRENCH COVERS** ..... 23
- » **CURB RAMPS** ..... 24
- » **MANHOLE GUARDS** ..... 8,24
- » **FLAGGER STATION & WORK AREA LIGHTING** ..... 25
- » **PARKING LOT SAFETY PRODUCTS**
  - Parking Stops, Speed Bumps, Speed Humps ..... 26,27
  - Portable Post Sign Stands ..... 28,29
  - Valet Parking Signs ..... 30
- » **SAFETY SIGNAGE & SIGN STANDS** ..... 31
- » **WHEEL CHOCKS** ..... 32

Visit our website [Plasticade.com](http://Plasticade.com) for additional information on our products. Our [Traffic Safety State Reference Guide](#) provides information on products certified for use in each state and includes product specifications and sheeting requirements. In addition, you will find detailed drawings, photographs, and assembly instruction sheets for our products on the website.



## PLASTICADE® Type I and Type II Barricades

All plastic and maintenance free, never rusts, needs painting, or leg straightening

- Molded hollow so it can be internally ballasted with up to 10 lbs. of sand (5 lbs. per leg)
- when internally ballasted, has a low center of gravity
- more likely to fold and fall down flat when hit, reducing vehicle damage
- less susceptible to being blown over

Hinges “click lock” for a positive interlock in the open position

Features a molded in handle where a flashing light can be attached

Available in white, yellow, and orange

Dimensions: 25"W x 45"H Weight: 16 lbs.

MASH Accepted, WZ-409, Meets MUTCD Standards



## FIBERCADE™ Type I and Type II Barricades



All plastic barricade - boards have “double-wall” design for strength and rigidity

Built from component parts, legs and boards, assuring easy replacement of damaged parts

Bottom board can carry a 35 lb. sandbag

Two mounting receptacles for flashing lights

Boards are available in three sizes (12"x24", 8"x24", and 3"x24")

Dimensions: 24"W x 43.3"H Weight: 16 lbs.

MASH Accepted, WZ-408, Meets MUTCD Standards

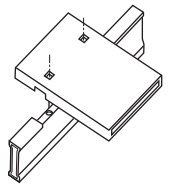

Holes are predrilled in the boards and legs for easy assembly when you purchase component parts

## ECONOCADE® Type I and Type II Barricades



All plastic, economical barricade, that is strong and stackable

Solid wall design; legs and boards are molded in one piece

Weighing 13.2 lbs., it is easy to handle, pack, and transport

Available in white, custom colors by special order

Dimensions: 24.4"W x 42.6"H

MASH Accepted, WZ-407, Accepted, Meets MUTCD Standards

## COMBOCADE™ Type I and Type II Barricades

Steel leg barricade with plastic Power™ Boards - Now 50% Stronger

Boards can be replaced, and legs can be replaced or repaired

45" steel legs, 14 gauge thickness, galvanized  
- white powder coated finish available by special order

Plastic, Double Wall Power™ Boards are strong and dense, will not bend, warp, crack, splinter, or peel

Bolt holes are molded into the plastic boards

Dimensions: 24.4"W x 42.6"H Boards: 12"x24", 8"x24", and 6"x24"

MASH Accepted, WZ-406, Meets MUTCD Standards

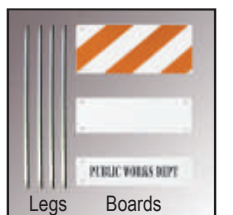

Purchase Combocades fully assembled or as component parts

Company Names can be Stenciled on any of the Barricades for Identification

# SAFETYCADE®

Stack more on your truck!  
- units use 65% less space than drums

Smaller footprint on the road  
- 12% narrower than tire rings  
- good for narrow shoulders

Quick set-up  
- spring loaded feet quickly release for placement

Lies flat when hit

Replaceable plastic sheeting panels  
- recessed panels are removable, just clip on new panels

Anti-skid pads on feet reduce movement in work zones

Feet come filled with 7.5 lbs. of sand each  
- optional ballast boots snap on feet adding 20 lbs. each

Molded-in light receptacle for "D" cell battery lights

Available in white

Overall Dimensions: 42.5"H x 33"W x 3"D Weight: 29 lbs.

MASH Accepted, WZ-410, Meets MUTCD Standards



Use the Safetycade Direction Indicator Barricade in the taper, paired with the Verticade in tangent areas for improved flow and safety in work zones



12" x 24" Top Panel  
8" x 24" Bottom Panel  
on two sides

# VERTICADE™

Smaller footprint on the road  
- 41% narrower than tire rings  
- good for narrow shoulders

12" x 36" panel for retroreflective sheeting on two sides

Replaceable plastic sheeting panels  
- recessed panels are removable, just clip on new panels

Compact stacking, feet fold for transport and storage

Quick set-up  
- spring loaded feet quickly release for placement

Lies flat when hit

Anti-skid pads on feet reduce movement in work zones

Feet come filled with 7.5 lbs. of sand  
- optional ballast boots snap on feet adding 20 lbs. each

Molded-in light receptacle for "D" cell battery lights

Available in white

Overall Dimensions: 43.5"H x 21"W x 3"D Weight: 27 lbs.

MASH Accepted, WZ-411, Meets MUTCD Standards



Optional Ballast Boot  
Snaps on feet of Verticade™ and Safetycade®



Lies flat when hit, reducing damage to unit and vehicle

# LO-PRO™ AIRPORT BARRICADE

Low-profile interlocking barricade system used to close taxiways, runways, and delineate construction areas

8 ft. long and 10 in. high barricade, units interlock

Durable construction, 25 lbs.  
- enhanced wall thickness on barricade bottom  
- molded reinforcing ribs add stiffness and strength

Connectors are molded into the barricade, no pins to lose  
- allows interconnected units to pivot in multiple orientations between 90° and 180°

7° angled sidewall  
- facilitates visibility  
- accepts 70"L x 6"H continuous retroreflective sheeting

Fill with up to 220 lbs. (26 gallons) of water  
- two fill holes and one drain hole

Accepts two styles of lights  
- 360° round, screw on airport lights  
- standard barricade, bolt on lights

Two flag mounts

FOD (foreign object debris) Free

Forklift access, recessed areas at bottom of barricade

Stackable for transportation and storage  
- multiple stacking lugs keep units in place while stacked

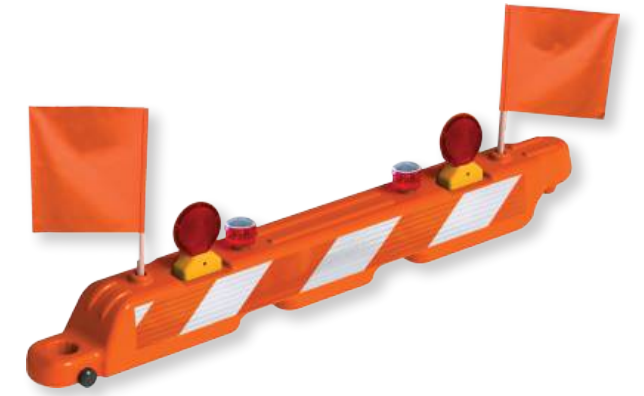

Meets FAA Advisory Circular No. FAA AC150/5370-2G



20" x 20" vinyl flag  
Stiffener keeps flag open  
36" L wood dowel

## 360° Red Solar LED Airport Lights



Ambient light sensing,  
- turns on automatically in low light  
- photocell sensitivity - 100-250 lux  
4 LED bulbs  
- brightness - 4.5 Candelas  
Flashes 50 to 55 times per minute  
Standard 2" straight pipe thread  
for easy installation  
Ni-Mh battery included  
- Sub C battery with flat top 1.2V 3400mAh high capacity

**WARNING**  
This product can expose you to nickel, which is a known to the State of California to cause cancer and birth defects or other reproductive harm.  
For more information go to [www.P65Warnings.ca.gov](http://www.P65Warnings.ca.gov)

## Water Fill Holes with Screw On Caps Double as 360° Round Airport Light Receptacles

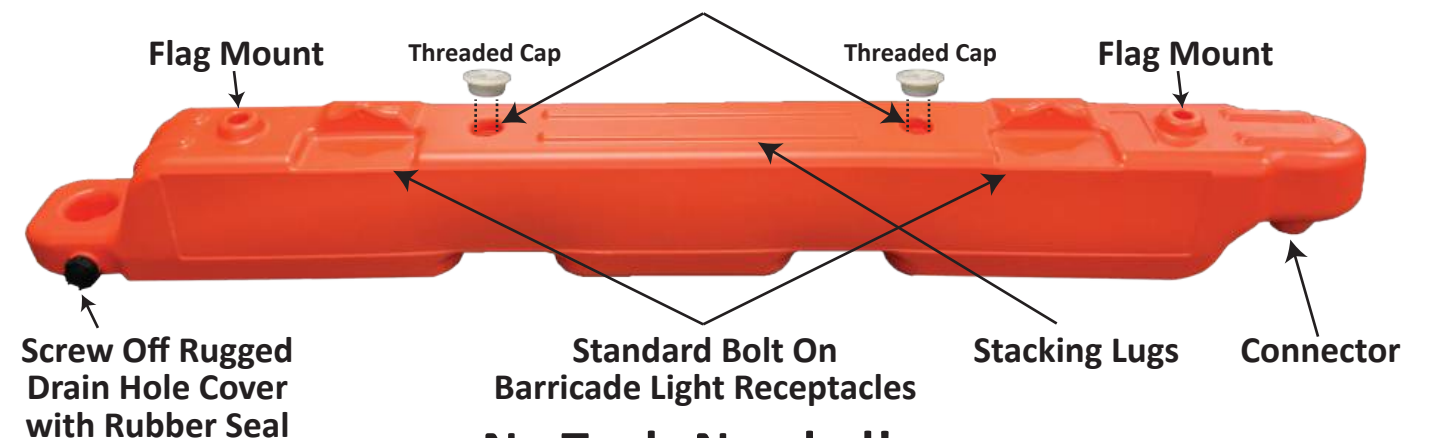

No Tools Needed!



# WATER FILLED BARRICADE SYSTEM

## LONGITUDINAL CHANNELIZING DEVICE



90° Turns



### Uses:

- Block off work zone areas from workers and public
- Provides visual pathway for vehicles and pedestrians
- Perimeter security
- Crowd control



# WATER FILLED BARRICADE SYSTEM

## LONGITUDINAL CHANNELIZING DEVICE

60"L x 36"H channelizing device , fillable with water or sand

Durable construction, impact resistant

- Conforms to any roadway design, can turn 90°
  - tongue and groove assembly
  - linked units secured with connector pin
  - quick assembly and breakdown

Lightweight, 50 lbs. when empty  
- no heavy machinery needed for installation

Stackable for transport and storage  
- 820 LFT/truck (164 units)

Forklift access, recessed areas at bottom of barricade  
- can be moved while filled with water

Fill with up to 72 gallons of water  
- every unit is leak tested

Light pocket for standard barricade light, use 5" light bolt

Accepts optional fence panels  
- 54"W fencing with 8'H - 3" diameter posts (covers 60")

Area for applying retroreflective striped sheeting

Standard in orange and white  
- custom colors available, 40 piece minimum

MASH Accepted WZ-387, Test Level 2, Meets MUTCD Standards

Made in the U.S.A.

Dimensions: 60"L x 24"W x 36"H  
Connected length: 60"  
Weight: Empty - 50 lbs.  
Water filled - 683 lbs.



Connector Pin - 33.8" L  
Links Units and Allows Them  
To Swivel 90°



Stackable for storage and transport



Optional fencing comes with panels, clamps and posts



# ADA PATHCADE™ BARRICADE

Multi-purpose Barricade System

- Crowd Control System
- Manhole Guard
- ADA Pedestrian Pathway System
- Longitudinal Channelizing Device

**ADA COMPLIANT  
&  
MASH APPROVED**



Multi-functional barricade system meets ADA requirements, 72"L x 38"H x 3"D  
- continuously detectable edge at barricade top and bottom

Exclusive tripod leg system, no sandbags needed when using all 3 feet  
- anti-trip foot on one side  
- two larger feet on other side  
- use only larger feet with sandbags for ADA Compliance

Easy handle turn deploys barricade feet!  
- unique soft grip handle system, quick turn moves feet out or back in

Stack 20% more  
- nesting system allows for 19 units to be stacked on pallet  
- lowers transportation costs  
- stacking lugs keep stacked units from shifting

Shape to any layout, units pivot 120°  
- 3 units in triangle layout for manhole guard

Robust dual connectors create easy to use linking system

Smooth, comfortable guardrail  
- rounded edge on top of panel

Four recessed sheeting areas, two on each side of panel, 8" x 50" ea.

Light shelves hold standard barricade lights, 2 per section

Holes for attaching signage to panel

Available in orange or white, with or without retroreflective sheeting

MASH Accepted, WZ-428, Meets MUTCD Standards

Made in the U.S.A.

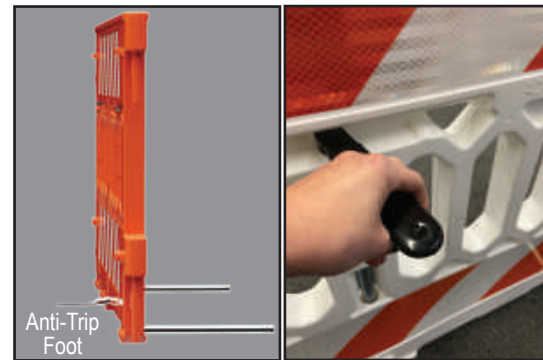

Anti-Trip Foot

Tripod Leg System

Handle turn Deploys Feet



Add Signs for Crowd Control



Create ADA Compliant Pedestrian Pathway



Use Three Units To Create Manhole Guard

# STRONGWALL BARRICADE

Limits access to work zones  
- provides a continuous path for motorists and pedestrians

No sandbags needed!

ADA Compliant, no trip hazard for pedestrians  
- meets or exceeds ADA Guidelines and MUTCD Standards

Linking sections are made up of two pieces that securely fit together  
- Top Wall - rugged polyethylene  
- Bottom Base - 43 lb. self weighted black base, with carry handle

Modular system can be shaped to any layout

Stable in windy conditions

Quick and easy to install

Anti-tamper linking system  
- difficult for unauthorized personnel to dismantle when linked

Compact stacking lowers transportation costs

Available in orange or white, with or without retroreflective sheeting

MASH Accepted WZ-328, Meets MUTCD Standards

Height - 38" with base  
Length - 43" end to end (40.4" connected length)  
Total Weight - 51 lbs.  
Sheeting - 6" x 30" on each side  
Base Dimensions:  
40.4"L x 15.5"W x 12"H, 43 lbs.

**43 lb. Base  
Eliminates  
Sandbags**



**ADA COMPLIANT  
&  
MASH APPROVED**

Create an ADA Compliant Walkway

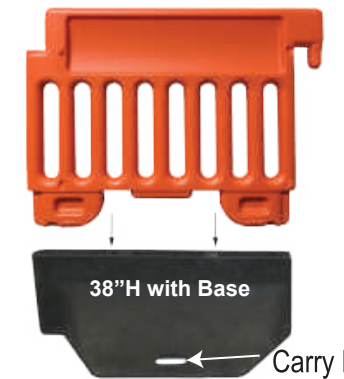

Carry Handle

# POWER™ BOARDS FOR BARRICADES

New blow molded boards have greater strength and durability  
- double wall creates stiffer, longer lasting board  
- will not bend, warp, crack, splinter, or peel

Hole punch-outs are molded into the board

Names can be stenciled on the boards for identification

Available in 3 sizes  
- 24"W x 12"H  
- 24"W x 8"H  
- 24"W x 6"H

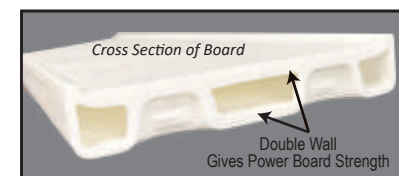

Double Wall Gives Power Board Strength

Boards are .65" thick



Barricade boards come in 3 sizes

# TYPE III & A-FRAME BARRICADE BOARDS

1" x 8" plastic boards come in 4', 6', 8', 10', and 12' lengths

Boards are .75" thick

High density polyethylene material resists fading, chipping, or splintering

Flat surface displays retroreflective sheeting  
- complies with MUTCD requirements

Hollow core extruded design  
- internal walls provide lightweight strength and durability

Can be used in various generic Type III Barricade designs accepted by FHWA

Order with or without drilled bolt holes for Type III Barricades



Extruded Hollow Core Design with Internal Walls for Strength and Durability



# POWER POST™, STEEL SQUARE TUBE, & ANGLE IRON TYPE III BARRICADES

## Six Options Available

- Power Post™ uprights with Volcano Rubber Base
- Power Post™ uprights with Steel Square Tube feet
- Power Post™ uprights with Angle Iron feet
- Steel Square Tube uprights with Steel Square Tube feet
- Steel Square Tube uprights with Angle Iron feet
- Angle Iron uprights with Angle Iron feet



## Power Post™ Type III Barricade

- Plastic posts save you time and money! easier to handle; set up and break down goes faster
- Lightweight but strong plastic square tube 67% lighter than steel square tube posts
- Impact resistant
- No rust or corrosion
- Uprights have holes for attaching boards and lights

### Volcano™ Rubber Base

- use with Power Post uprights
- 43.25 lbs., holds posts up to 1.75" x 1.75"
- contains steel base plate for upright insertion
- two carry handles
- stacks for transportation and storage

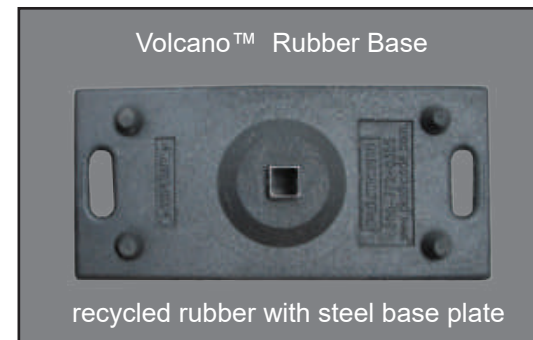

### Steel Square Tube Feet

- Feet are 14 gauge, galvanized, hot rolled high carbon steel

### Angle Iron Feet

- Feet are 10 gauge steel, galvanized

Plastic boards available in 4', 6', 8', 10', and 12' lengths  
- retroreflective sheeting on one or both sides

Quick removal of uprights from feet  
- allows for short term or permanent placement

Easy to assemble and replace parts if necessary

Accepts two flashing lights

Dimensions:

- Power Post Upright - 1.75" x 1.75" x 63" - 3 lbs.
- Steel Square Tube Foot - 1.75" x 1.75" x 60", Riser - 6"H - 10 lbs.
- Angle Iron Foot - 1.5" x 1.5" x 60", Riser - 6"H - 7 lbs.
- Volcano Rubber Base - 30.25"L x 14"W, 43.25 lbs.

## OPTION #1



**Power Post Uprights with Volcano™ Rubber Bases**  
MASH Accepted WZ-343  
Meets MUTCD Standards

## OPTION #2



**Power Post Uprights with Steel Square Tube Feet**

MASH Accepted WZ-327  
Meets MUTCD Standards

## OPTION #3

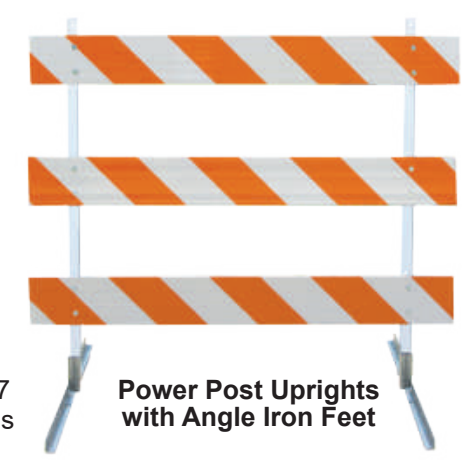

**Power Post Uprights with Angle Iron Feet**

# STEEL SQUARE TUBE & ANGLE IRON TYPE III BARRICADES

## Steel Square Tube

- Square shape provides superior wind load capabilities and inhibits warping
- Uprights and feet are 14 gauge, galvanized, hot rolled high carbon steel
- Prepunched universal mounting holes - 7/16" dia.

## Angle Iron

- Uprights are 10 gauge, galvanized steel
- Holes for boards 11/32" dia. and holes for lights 9/16" dia.
- Feet are 10 gauge steel, galvanized

Plastic boards available in 4', 6', 8', 10', and 12' lengths  
- retroreflective sheeting on one or both sides

Quick removal of uprights from feet  
- allows for short term or permanent placement

Easy to assemble and replace parts if necessary

Accepts two flashing lights

Dimensions: Steel Square Tube Upright - 1.75" x 1.75" x 63"  
Steel Square Tube Foot - 1.75" x 1.75" x 60", Riser - 6"H  
Angle Iron Upright - 1.5" x 1.5" x 63"  
Angle Iron Foot - 1.5" x 1.5" x 60", Riser - 6"H

NCHRP-350 Accepted, Meets MUTCD Standards

## OPTION #5



**Steel Square Tube Uprights with Angle Iron Feet**

Holes for mounting flashing lights

## OPTION #6

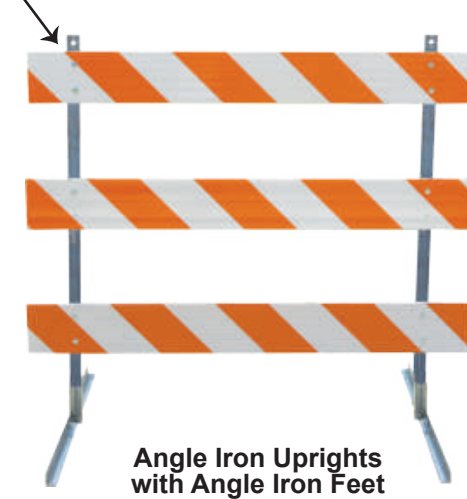

**Angle Iron Uprights with Angle Iron Feet**

## OPTION #4



**Steel Square Tube Uprights & Feet**

# PLASTICADE® BREAK-AWAY TYPE III BARRICADE

All-plastic and collapsible

Available with five board lengths, 1" x 8" boards, 4', 6', 8', 10', or 12' long

Easier to transport, install, and store than wood or steel Type III Barricades

Boards are available sheeted (one or both sides) or unsheeted

Accepts two flashing lights

Dimensions: Upright - 3.5" x 3.5" x 5' Base - 1.5" x 5.5" x 5'

MASH Accepted WZ-299, Meets MUTCD Standards

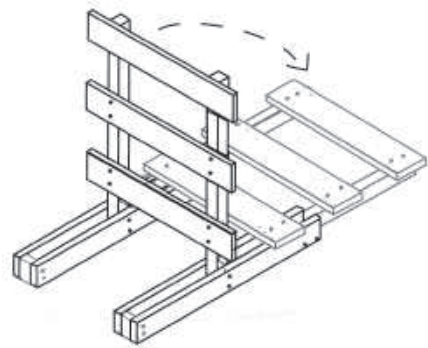

Assembled, the Type III Barricade easily folds down for transport and storage



# SENTINEL™ TYPE III BARRICADE

The Sentinel Type III Barricade is all plastic and easy to assemble

Base consists of two pieces, that snap together, no hardware required

Available with 1" x 8" boards, 4' or 6' long

Boards are available sheeted (one or both sides) or unsheeted

Base can be ballasted with sand, sandbags  
- or with water (in warmer climates)

Dimensions: 36"W x 48"D x 68.8"H Weight: 15 lbs.

MASH Accepted WZ-302, Meets MUTCD Standards



Upright Snaps into the Base



# WATCHTOWER™ STACKER CONE

42" tall

Stack up to 20% more on your truck!  
- new compact nesting design

Strong, ergonomic handle  
- speeds placement on job  
- fits two hands to make lifting with base easier  
- string caution tape through handles

Recessed area protects sheeting

Use with 10, 16, or 30 lb. recycled rubber base

Accepts same bases as our Navicade™ delineator  
- reduces your base inventory

Customize with your company name or logo

Available in orange and yellow

Dimensions: 47.5"H x 11"W  
Weight: 2.25 lbs.

MASH Accepted, Meets MUTCD Standards

Made in the U.S.A.



Ergonomic handle makes placement of cones easy, even with heavy base



String caution tape through handles



# PVC TRAFFIC CONES

High visibility PVC injection molded cones

- 36" in 10 lbs. and 12 lbs. fluorescent orange
- 28" in 7 lbs. and 10 lbs. fluorescent orange and 7 lbs. lime green
- 28" Slimline in 7 lbs. and 10 lbs. fluorescent orange
- 18" in 3 lbs. fluorescent orange and lime green

Recycled rubber cone weights available for 28" & 36" cones  
- 5 lbs. and 7 lbs.

Fluorescent orange or lime green color is molded throughout  
- resists fading  
- provides high visibility protection

One piece design - cone is permanently molded to black base  
- won't separate when hit by a vehicle  
- rubber base designed to grip the road

36" & 28" cones have hand-grip at top

Durable and reboundable

Stable on the road, won't be blown over

Stackable for storage, no sticking when removed

36" & 28" cones have recessed areas that accept high intensity white collars  
- 3M™ collars have excellent wide angle retroreflectivity

Stenciling available

MASH Accepted, Meets MUTCD Standards

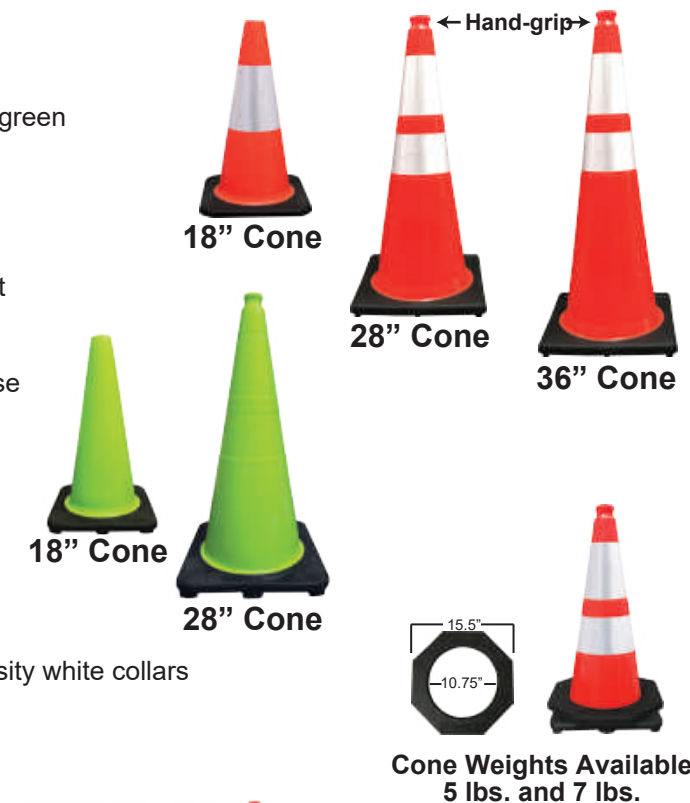

Cone Weights Available 5 lbs. and 7 lbs.

# TELESCOPING CONE BARS

- Two sizes
- Expands from 4' to 7'  
available in reflective orange on white and reflective yellow on black
- Expands 5.5' to 10', 5 lbs. in reflective orange on white
- Quick installation to provide high visibility barrier
- Portable, versatile, & lightweight, 7' - 2 lbs., 10' - 5 lbs.





# COMMANDER™ TRAFFIC DRUM

Enhanced Material Formulation for Superior Reboundability & Durability

Extended Usable Life

- Power Dome
- handle and Dome interfuse creating strength
- thicker wall
- resists denting

20% More Per Truckload

- Tighter Stacking & Packing
- maximizes transport and storage space

Tire Locking Ring Design

- inhibits movement of drum on road surface
- wedge fit created from skirt ramp and elliptical shaped bottom
- textured skirt increases friction and grabs tire
- anti-roll design, flat sections on two sides

Revolutionary Light Folding, Light Mounting Design

- light easily turns for stacking

Comfort grip handle

Customize drum with molded in name or logo

Five tier design to maximize reflective sheeting

Available in low or high density polyethylene

Overall Dimensions: 39.7"H x 23.5"W Weight: 8 lbs.

MASH Accepted, Meets MUTCD Standards

Made in the U.S.A.

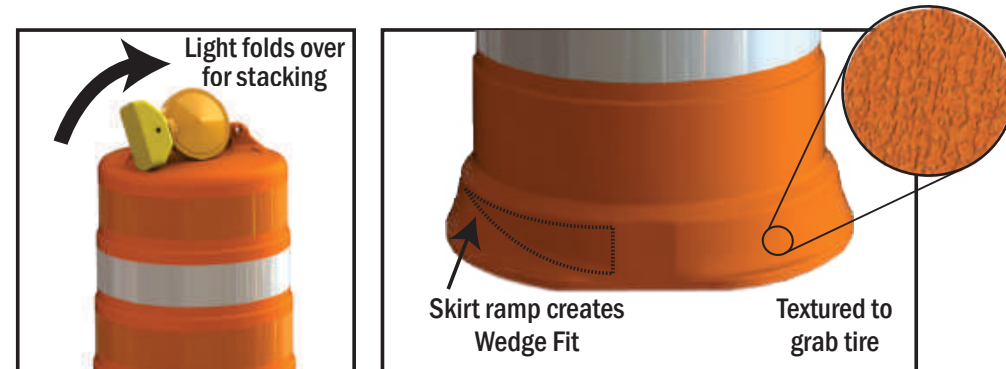

# LANE CHANGER™ B500 AND REBOUNDER XD B500 TRAFFIC DRUM

Impact resistant polyethylene

- Lane Changer B500 - high density polyethylene
- Rebounder XD B500 - low density polyethylene

Use with a tire ring

Domed top sheds debris and water

Five tier design protects sheeting when stacked

Comfortable grip, fracture resistant handle

Double light mount

Locking base grips tire ring

Customize drum with molded in name or logo

Overall Dimensions: 41.5"H Weight: 8 lbs.

MASH Accepted, Meets MUTCD Standards

Made in the U.S.A.



# B400 TRAFFIC DRUM

Uses snap on recycled rubber base, 25, 35, or 40 lbs.

- ribbed bottom for easy base attachment
- drum can be dragged without separation of top and base

Rounded ergonomic handle

5 tier design, protects sheeting when stacked

Two light mounts

Four 5" wide anti-rotation claws, keep drums facing traffic

Available in high density polyethylene

Customize drum with molded in name or logo

Overall Dimensions: 40"H Weight: 8 lbs.

MASH Accepted, Meets MUTCD Standards

Made in the U.S.A.

Snap On Recycled Rubber Bases





## NAVICADE™

42" channelizer (50" with handle)

Slim design  
- perfect for narrow roadways where space is an issue

Very durable, designed to rebound after impact

Oversized handle  
- easy to grab with gloved hand or light attached

Stackable with or without base for easy transport and storage

42" available with 4 bands of sheeting  
- choose 6" and/or 4" bands

Solid recycled rubber bases  
- 10, 16, and 30 lbs. (uses same bases as C42 Channelizers)

Customize with molded in name or logo  
- stenciling available

Overall Dimensions: 50.4"H x 7.6"W Weight: 3 lbs.

MASH Accepted WZ-301, Meets MUTCD Standards

Made in the U.S.A.



## NAVICADE™ 28

28" channelizer (35.5" with handle)

Slim design  
- perfect for narrow roadways where space is an issue

Very durable, designed to rebound after impact

Oversized handle  
- easy to grab with gloved hand or light attached

Stackable with or without base for easy transport and storage

28" available with 2 bands of sheeting  
- choose 6" and/or 4" bands

Solid recycled rubber bases  
- 10, 16, and 30 lbs. (uses same bases as C42 Channelizers)

Customize with molded in name or logo  
- stenciling available

Overall Dimensions: 35.5"H x 7.75"W Weight: 3 lbs.

MASH Accepted, Meets MUTCD Standards

Made in the U.S.A.



10 or 16 lb.  
base



30 lb.  
base

Light can only be used  
on 42" Navicade



Unique angled handle  
allows workers wearing  
gloves to easily set up  
the Navicade, even with  
light attached

## C42 CHANNELIZER AND REBOUNDER XD C42 CHANNELIZER

Impact resistant polyethylene  
- C42 - high density polyethylene  
- Rebounder XD C42 - low density polyethylene

42" channelizer (48.9"H with handle)

Slim design with five tiers  
- protects sheeting when stacked

Comfortable grip, fracture resistant handle

Double light mount

Handle has holes to mount a sign

Reinforced flange as bottom, tightly holds rubber base

Solid recycled rubber bases  
- 10, 16, and 30 lbs. (uses same bases as the Navicades)

Customize with molded in name or logo  
- stenciling available

Overall Dimensions: 48.9"H x 6"W, tapers to 4" Weight: 3 lbs.

MASH Accepted (without light), Meets MUTCD Standards

Made in the U.S.A.



## GEMSTONE™ VERTICAL PANEL

Oversized handle with comfort grip - can be picked up easily, even with light attached

NEW Thicker Flange! More plastic to hold onto base  
- increased rigidity from larger ribbing  
- eliminates splitting and cracking

Recessed panel protects reflective sheeting - 36"H x 8"W

Flashing light mounting receptacle

Solid recycled rubber base in 20 or 30 lbs.

Available in orange or white

Dimensions: 44.5"H x 14.75"W Weight: 4 lbs.

MASH Accepted WZ-300, Meets MUTCD Standards

Made in the U.S.A.



20 lb. base



30 lb. base

**New Stronger Flange!**  
Stands Up To Extreme Heat  
and Intensive Use

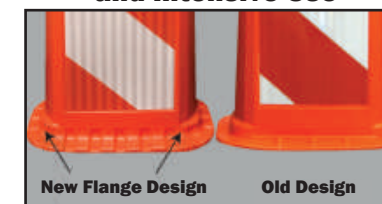

The handle is easy to grab,  
even with light attached



# WATCHTOWER™ DELINEATOR

Watchtower handle has ergonomic, comfort grip  
 - dome cap provides strength and durability  
 - easy placement and pick-up

Two sizes  
 - 42" (47"H with handle)  
 - 28" (33.6"H with handle)

Recessed areas accept two bands of sheeting  
 - protects retroreflective sheeting from rips and scratches

Flange on bottom grabs base for tight fit

Durable polyethylene  
 - bright orange for visibility

Recycled rubber bases, 8, 10, 12, and 18 lbs.

Weight: 42"H - 1.7 lbs., 28"H - 1.25 lbs.

MASH Accepted, Meets MUTCD Standards



Great for Caution Tape



Dome Cap Provides Strength & Durability To Handle

Easy Grip Handle

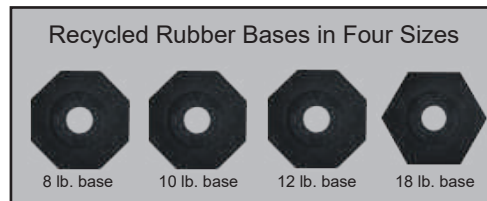

# OPEN TOP DELINEATOR

Two sizes  
 - 42"  
 - 28"

Post diameter - 4"

Flange on bottom grabs base for tight fit, 5.375" dia.

Quick to set up

Reflective bands, 3" or 4" wide

Durable polyethylene

Recycled rubber bases, 8, 10, 12, and 18 lbs.

Weight: 42"H - 1.7 lbs., 28"H - 1.1 lbs.

MASH Accepted, Meets MUTCD Standards

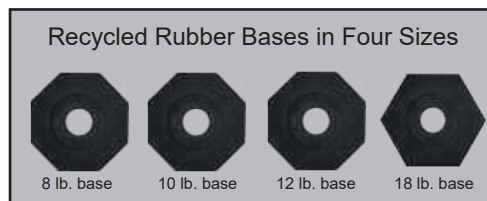

# OMNI™ A-FRAME BARRICADE

Great for Crowd Control and Road Closures

Versatile, accepts many types of boards  
 - Plasticade® I-Beam boards  
 - Plasticade® 1" x 8" boards (Type III boards)  
 - other plastic boards (I-Beams, thin rails, panels)  
 - wood boards

20% heavier than Plasticade® A-Frame  
 - solid wall design

Customize nameplate with your name or logo

Stacking lugs  
 - make transportation and storage easy

Flashing light mounting receptacle on leg

Use with one board or two

Sold in sets or as component parts

Leg Dimensions: 40"H x 28.6"W

Weight: 6 lbs.



I-Beam Boards have a unique design that adds to the rigidity of the unit. The recessed area for sheeting helps to protect the sheeting from damage. Available in 6', 8', & 10' lengths.



1" x 8" Boards are a hollow core extruded design. Internal walls provide lightweight strength and durability. Available in 6', 8', 10', & 12' lengths.

# PLASTICADE® A-FRAME BARRICADE

Great for Crowd Control and Road Closures

Accepts only Plasticade® I-Beam boards

Molded hollow  
 - may weight internally with dry sand

Stacking lugs  
 - make transportation and storage easy

Flashing light mounting receptacle on leg

Use with one board or two

Sold in sets or as component parts

Leg Dimensions: 42"H x 28"W (board opening - nominal 2"W x 8"H)

Weight: 5 lbs.

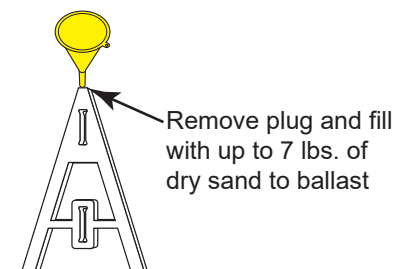

Remove plug and fill with up to 7 lbs. of dry sand to ballast

I-Beam Board

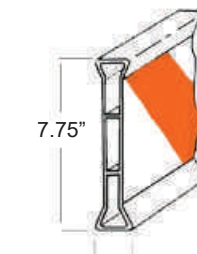

1.75" I-Beam's recessed face protects the sheeting



# CROWDCADE™ Crowd Control Barricade

6' durable plastic barricade  
with strong plastic legs and rubber feet

- Sturdy, and durable - thick, double wall panel
- Feet won't break off from panel
  - stable, recycled rubber feet, securely attached to panel
- Easy stacking, no tangling of feet
  - feet rotate flat for stacking
  - molded-in lugs keep units from sliding when stacked
- Tamper resistant linking bracket
  - prevent in-line barricades from being pulled apart
- Linking bracket accommodates various configurations
  - units pivot on bracket and adjust to uneven ground
- Holes for bolting on signs (one side)
- Panels on both sides for retroreflective sheeting
- Available in orange and white
  - custom colors with minimum order quantity
- Dimensions: 74" x 39.5"
- Connected Length: 6'
- Weight: 32 lbs.



Panels on both sides for sheeting

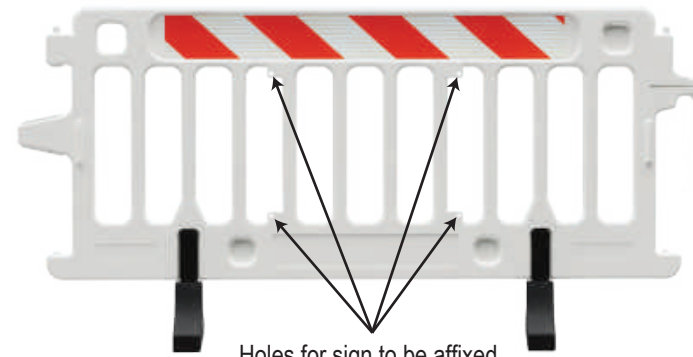

Holes for sign to be affixed



connected  
unlocked



connected  
locked



feet rotate  
for stacking



Connected length is 6 feet for each barricade

# CROWDCADE™ DELUXE Crowd Control Barricade

Deluxe 7' thick walled,  
plastic barricade with steel legs and feet

- Sturdy and extra durable
  - feels as solid as steel, but won't rust
  - 50% thicker double wall panel, prevents warping or bending
- Superior stability, stands up to large crowds
  - steel legs are integrated with barricade panel, preventing tip-over
- Anti-trip, flat steel feet are securely welded to steel legs
  - powder coated finish
- Feet rotate and lock for compact stacking
  - molded-in lugs keep units from sliding when stacked
- Tamper resistant locking hooks create strong connections
  - prevent in-line barricades from being pulled apart
- Double locking hooks accommodate various configurations
  - units pivot on hooks and adjust to uneven ground
- Unique Quick-Change™ system, easy to slide in signs
  - signs held in by stay tabs™ on both sides of barricade
  - holes for bolting signs if required
- Available in orange and white
  - custom colors with minimum order quantity

Dimensions: 86.25" x 42"  
Connected Length: 7'  
Weight: 35 lbs.



Steel, Anti-trip feet



Quick-Change™,  
holds two 29.5" x 26" signs  
just slide signs in...



connected  
unlocked



connected  
locked



feet rotate and lock  
for stacking

To lock feet, rotate foot and push down on top of barricade. To release lock, stand on foot and pull up barricade.



Connected length is 7 feet for each barricade



# Plasticade® Modular Glare Screen

## Vertical Blade and Rail System

- Attach to existing barrier wall
- Reduce headlight glare from opposing traffic
- Curtail gawking in work zones
- Prevent pedestrians from crossing barrier

Reduces installation time!

- Unique "Snap in Place" design
  - quick and easy installation and removal on-site
  - limits worker exposure to dangerous work zones

Reduces labor costs!

- No time-consuming preassembly needed

Reduces transportation costs by 65% or more

- Fit over 3 miles of glare screen on one semi truck, compared to 1 mile of competitor's product

Reduces storage space needed by 80% or more

- quick to disassemble and store
- compact stacking of rails and blades

Blades are repositionable on-site for barrier wall relocation

- only two blades need to be removed for relocation
- base rail remains in place

Standard product is for use on left side of traffic

- can be provided for use on both left and right sides

Rail mounts flush on barrier wall eliminating rail fractures

All polymer plastic

- no fiberglass splinters
- no rust
- durable and long lasting

6"W blades

- available in heights 18" to 24", other heights upon request

6"W rails

- available in various lengths up to 15'



22° angled blades reduce glare

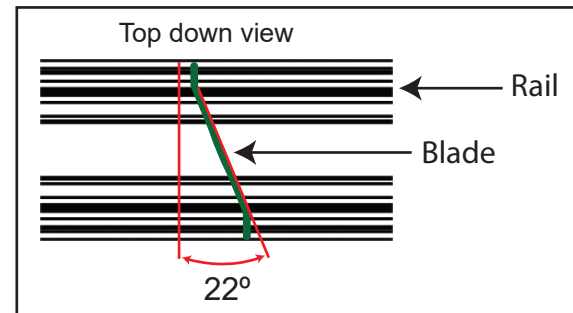

Both rails and blades stack compactly for transportation and storage

Plasticade® Modular Glare Screen stacks compactly saving you money on transportation!



Fit 1 mile of glare screen on 5 pallets

VS.



Takes a semi truck to hold only 1 mile of the competitor's product

Plasticade® Modular Glare Screen assembles quickly on-site, saving you money on labor!

## 12' Barrier Wall

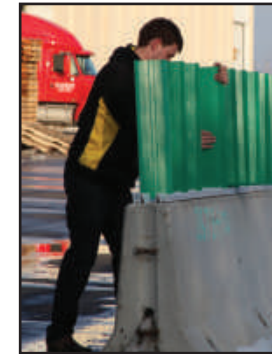

Assemble at job site in 37 seconds  
Only 11 pieces to assemble!

VS.



Competitor's must be preassembled in a warehouse  
A 12' barrier has 121 pieces to assemble

Blades snap into rail.

Place notch in blade under lip in rail. Push down into slots. Push second notch under second rail lip.

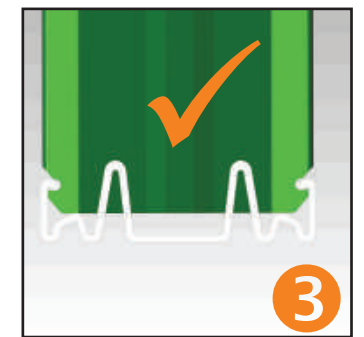
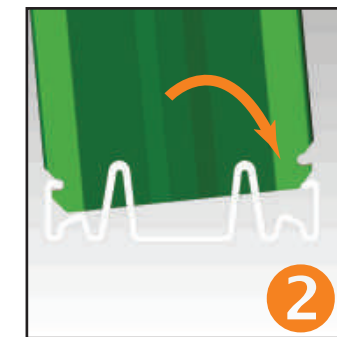
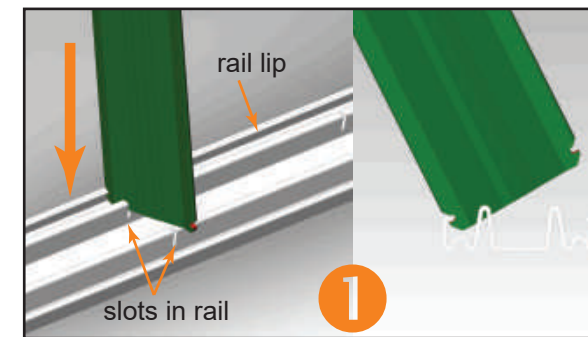

Removal Tool



Place removal tool near a blade.  
Pull back on tool and rail to release blade from rail lip.



# STOP/SLOW PADDLES & SIGNS

## Available Types:

**Screw On Handle, optional telescoping pole**

**Bolt On Handle, optional telescoping pole**

**Signs Only**



## Screw On Type

Paddle screws on and off to change between handle & telescoping pole

Aluminum handle is 10"L  
- rubber comfort grip

Two sided sign, STOP/SLOW  
- 18" sign available in ABS or corrugated plastic sheet  
- three grades of retroreflective sheeting

Optional screw on telescoping pole, fiberglass  
- expands to over 84"L  
- strong, durable ABS clamp, push clamp lock to hold pole at desired height  
- rubber comfort grip handle, 6" long handle fits large hands  
- rounded plastic tip at pole bottom, makes paddle turn easy  
- non-conductive and lightweight

Meets MUTCD Standards

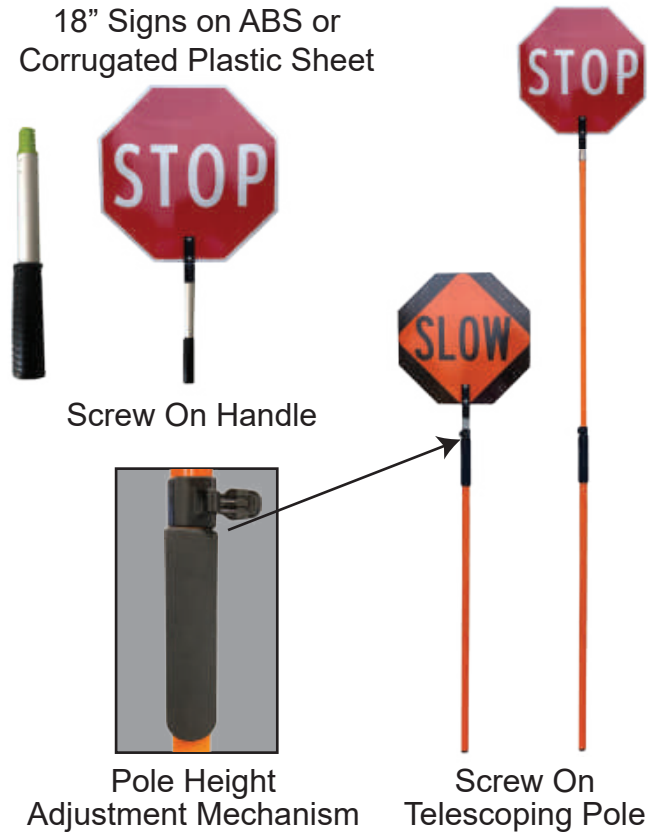

## Bolt Mounted Type

Paddle is mounted directly to handle or telescoping pole with included bolts

8"L Handle or Telescoping Pole  
- fiberglass, lightweight, and non-conductive  
- 4" PVC black handle

Two sided sign, STOP/SLOW or STOP/STOP  
- 18" and 24" available in ABS  
- three grades of retroreflective sheeting  
- easy to change or replace sign paddle

Telescoping pole  
- expands to over 84"L  
- pull sign up to expand pole then screw tight to lock pole at desired height  
- rubber end cap at pole bottom

Meets MUTCD Standards

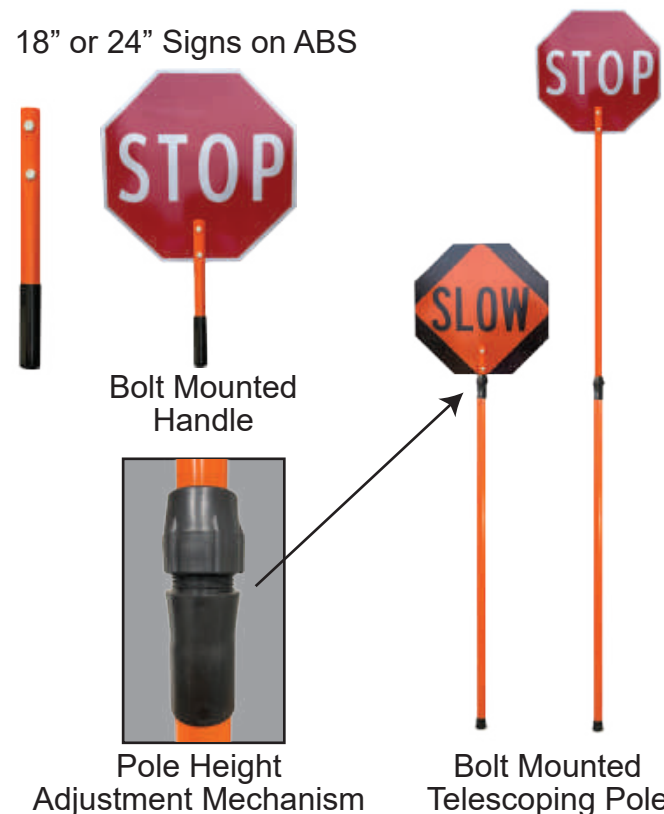

# TRENCH COVERS

## A better trench cover

- Exceptionally rigid, yet lighter than steel
- Easier & safer to lift into place than steel
- More stable & durable than plywood
- Less street noise
- High visibility yellow
- Anti-slip surface
- Graduated edge prevents tripping
- No scrap value for metal thieves
- No cold patch needed
- Rot & corrosion resistant

## Strong, Secure, & Safe Solution



Steel Plates with Cold Patch

Plasticade Trench Covers

## Trench Covers - 35" & 27"

Two sizes  
- designed to cover trenches up to 35" and 27"

Takes the weight of a vehicle up to 4,410 lbs

Anti-slip surface

Deters metal thieves

Beveled edge prevents tripping

Molded from a single piece of fiberglass composite  
- underside has ribbed framework for added strength

Secure with 4 bolts

Available in yellow

35" Trench Cover Dimensions:  
63"L x 47.2"W x 1.18"H, 73 lbs.

27" Trench Cover Dimensions:  
47.2"L x 31.5"W x 0.93"H, 26.5 lbs.



High Visibility, Anti-slip Surface

## Pedestrian Trench Cover

Ideal for Sidewalk Construction

For Pedestrians Only - takes up to 553 lbs.

Covers trenches up to 27.5"

Anti-slip surface

Smooth rubber edge greatly reduces tripping hazard

Resists sliding, no need to bolt down  
- flexible material which grips the surface underneath

Available in yellow

Overall Dimensions: 44.3"L x 44.3"W x 0.7"H, 62 lbs.





# CURB RAMPS

## Safekerb Ramp

- Ramp adapts to curb heights from 3" to 6.3"
- Withstands loads up to 553 lbs.
- High visibility, anti-slip, textured surface
- Raised sides prevent vehicle run off
- Molded from high density polyethylene
- Stacks for transport and storage
- Bolt to road and walkway surface for added stability
- Available in yellow
- Overall Dimensions: 50"L x 29.5"W, 13.2 lbs.



## Safekerb Supagrip Ramp

- Ramp adapts to curb heights from 2.5" to 6"
- Withstands loads up to 772 lbs.
- Flexible black edge reduces unwanted movement
- High visibility, anti-slip, textured surface
- Raised sides prevent vehicle run off
- Molded plastic won't rust
- Stacks compactly for transport and storage
- Bolt to road and walkway surface for added stability
- Available in yellow
- Overall Dimensions: 50.2"L x 29.9"W, 22 lbs.



# SAFEGATE MANHOLE GUARD

Ideal for Utility Work

- Nonconductive (dielectric), no metal used
- Great for protecting any area requiring temporary restriction of access
- Hinged clips make it easy to configure sections into rectangles of various sizes
- Locking clamp connects straight sections
- Folds up easily for storage and sets up quickly
- Carry handles for transport
- Longer life than metal, replacement sections available
- Available in yellow
- Dimensions for single section: 39.4"H x 29.5"W, 4.4 lbs.

**Nonconductive  
(no metal used)**



Optional retroreflective sheeting increases visibility

# FLAGGER STATION & WORK AREA LIGHTING

- 8 foot light elevation
- Collapsible aluminum extension mast - cam lock adjustments with retractable cable
- Battery rated for 500+ charge cycles - push to test voltage meter
- DC Power Port - operate unit with external 12 VDC power - run other DC powered electrical devices
- Charge with clamp style jumper cables - can jump start vehicle
- Lamp heads are independently, directionally adjustable
- Yellow LED flasher on unit for added safety
- Legs stable on uneven ground, retract for storage
- Weatherproof case
- Lifetime warranty on light heads
- One year replacement warranty on battery and charger
- Weight: 44 lbs. Storage Dimensions: 26"H x 17.5"W x 8"D



Sets Up In Seconds



Dual LED Light Head  
4000 Total Lumens (2,000 each light head)  
24 Watts, 2 amps, for the two heads  
Full Charge Run Time:  
• 14+ hrs. with both light heads on  
• 25+ hrs. with one light head on

**WARNING**  
This product contains a sealed lead acid battery which can expose you to chemicals including Lead and Sulfuric Acid, which are known to the State of California to cause cancer and birth defects or other reproductive harm.  
For more information go to [www.P65Warnings.ca.gov](http://www.P65Warnings.ca.gov)

### Internal Battery Specifications

- 12 VDC sealed 35 amp hour AGM lead acid battery
- Built in 110-240 VAC, 50/60 Hz
- UL approved 3 amp charge system
- Safely stored/operated at -40°F to 140°F
- Recommend continuous charging when light is not in use - if fully depleted, may require 24 hours to fully recharge

### Light Head Specifications

- IP-68 rated dust proof and waterproof
- 60° beam pattern
- Anodized aluminum frame with a polycarbonate lens



115 VAC power and DC to DC power cords included



Charge DC Powered Electrical Devices (DC computer adapter not included)



# PARKING LOT SAFETY PRODUCTS

Resistant to weather, oil, salt, moisture, UV light, and temperature

Will not warp, chip, or crack

Never needs painting, durable striping  
- molded-in reflective marking tape

Flexible, conforms to surface contours

Easy one person installation  
- install on asphalt or concrete (hardware sold separately)

Removable for road surface maintenance or snow plowing

**Installation Hardware**



- Concrete
  - 4 1/2" Lag Bolt with Washer & Shield for Speed Bumps & Speed Humps
  - 6" Lag Bolt with Washer & Shield for Car Stops
- Asphalt
  - 14" Re-bar Spike with Washer
- Epoxy can be used in addition to or as a replacement for the hardware in certain applications. See the installation instructions on our website.

## Speed Humps

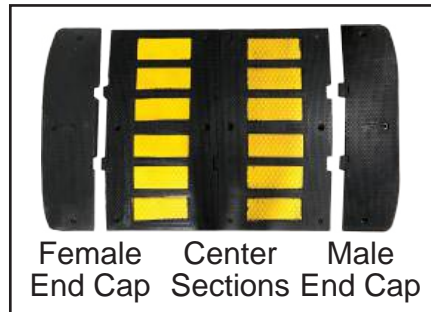
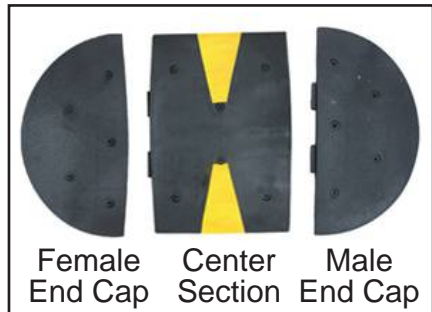

### Standard Speed Humps

Available in 24" sections, with 17.5" end caps  
- attach sections together to create custom length

For traffic speeds 15 mph or less

Gentler than speed bumps  
- good for heavy truck traffic areas

Reflective stripes in yellow

Dual bottom channels for drainage  
- protects wire, hose, or pipe to 3/4" dia.

Made in the USA using recycled rubber

End caps sold separately

Dimensions: 24"L x 36"W x 2.4"H sections  
connected length 23.5", 52 lbs.  
end caps 17.5"L x 36"W x 2.4"H, 23 lbs.



Back View

### Premium Textured Speed Humps

Available in 20" sections with 10" end caps  
- attach sections together to create custom length

Use in heavy traffic areas

Textured surface helps with traction

Made of durable vulcanized rubber  
- withstands extreme temperatures without cracking

Yellow stripes are UV stabilized synthetic rubber  
- non-wearing color

End caps sold separately

Dimensions: 20"L x 35"W x 2"H sections,  
connected length 19", 38 lbs.  
end caps 10"L x 35"W x 2"H, 14 lbs.



Back View

# PARKING LOT SAFETY PRODUCTS

## Speed Bumps



End Caps are optional



### Low Profile Speed Bump

2" High, 6' sections, made from recycled rubber

Reflective yellow tape is embedded in the rubber  
- increases visibility

Good for alleys, reduces speeds 1-5 mph

Cut with a utility knife if necessary

Optional cat eye reflectors

Dual bottom channels for drainage, protects wire, hose, or pipe

End caps and hardware sold separately

Made in the USA

### Standard Speed Bump

2.5" High, 6' or 4' sections, made from recycled rubber

Reflective yellow tape is embedded in the rubber,  
increases visibility

Good for parking lots & slow roadways  
- reduces speeds 2-5 mph

Cut with a utility knife if necessary

Optional cat eye reflectors

Dual bottom channels for drainage, protects wire, hose, or pipe

End caps and hardware sold separately

Made in the USA

## Parking Stops



Use in parking lots and garages  
- protects garage walls, delineates spaces

Available in 6 foot or 4 foot lengths

Maintenance Free

High visibility at night  
- reflective stripes in yellow or white

Made in the USA using recycled rubber



### Premium Textured Speed Bump



Comes with 8 Cat Eye Reflectors

### Premium Textured Speed Bump

2" High, 6' sections

Use in heavy traffic areas on low speed roadways

Reduces speeds 1-5 mph

Textured, vulcanized rubber performs well in extreme temperatures

Cat eye reflectors increase visibility at night

5 synthetic rubber yellow stripes, won't degrade

Dual bottom channels for drainage  
- protects wire, hose, or pipe

End caps and hardware sold separately

Dimensions (nominal) for Premium Speed Bump

2" High	72"L x 12"W x 2"H, 52 lbs.
End Caps	6"L x 12"W x 2"H, 3.5 lbs.

Dimensions (nominal) for Low Profile & Standard Speed Bumps

2" High	72"L x 12"W, 40 lbs.
End Cap	7"L x 12"W, 2.25 lbs.
2.5" High	48"L x 12"W, 35 lbs.
2.5" High	72"L x 12"W, 52 lbs.
End Cap	7"L x 12"W, 3.5 lbs.

Back View



Channels for Drainage



Dimensions (nominal)  
72"L x 6"W x 4.5"H, 35.5 lbs.  
48"L x 6"W x 4.5"H, 30 lbs.



# PARKING LOT SAFETY PRODUCTS

## Portable Sign Posts

with the Power™ Post Advantage

### Square Post = Stable Signs No Twist or Wobble!

Plastic Square Power Post™

- Two lengths - 60" and 72"
- Two colors - white and black
- Lightweight
- Post will never rust!

Predrilled holes for many sign sizes

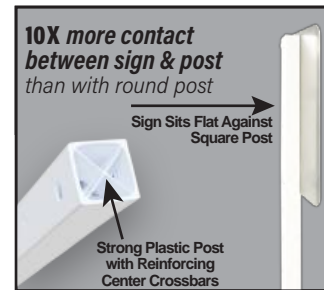

### Roll-A-Post™ Plastic Base

Durable, thick walled plastic bases in two sizes  
- no rust, dents, or cracking

Wheels for easy relocation  
- sturdy plastic wheels come pre-installed

Square plastic post eliminates sign twisting  
- available in white and black  
- no special bracket needed  
- cap for top of post included

Withstands strong winds without tipping over when filled with sand

Large fill holes

Lightweight plastic reduces shipping costs

Hardware for attaching a sign included

Made in the U.S.A.

Available Colors

Roll-A-Post 18: black, yellow, red, and blue  
Roll-A-Post 24: black and yellow  
- custom colors with minimum order qty.

### Sign Sizing Guide

18: use with signs 24" x 24" or smaller  
recommendation based on ballast of 80 lbs.

24: use with signs 26"W x 38"H or smaller  
recommendation based on ballast of 150 lbs.

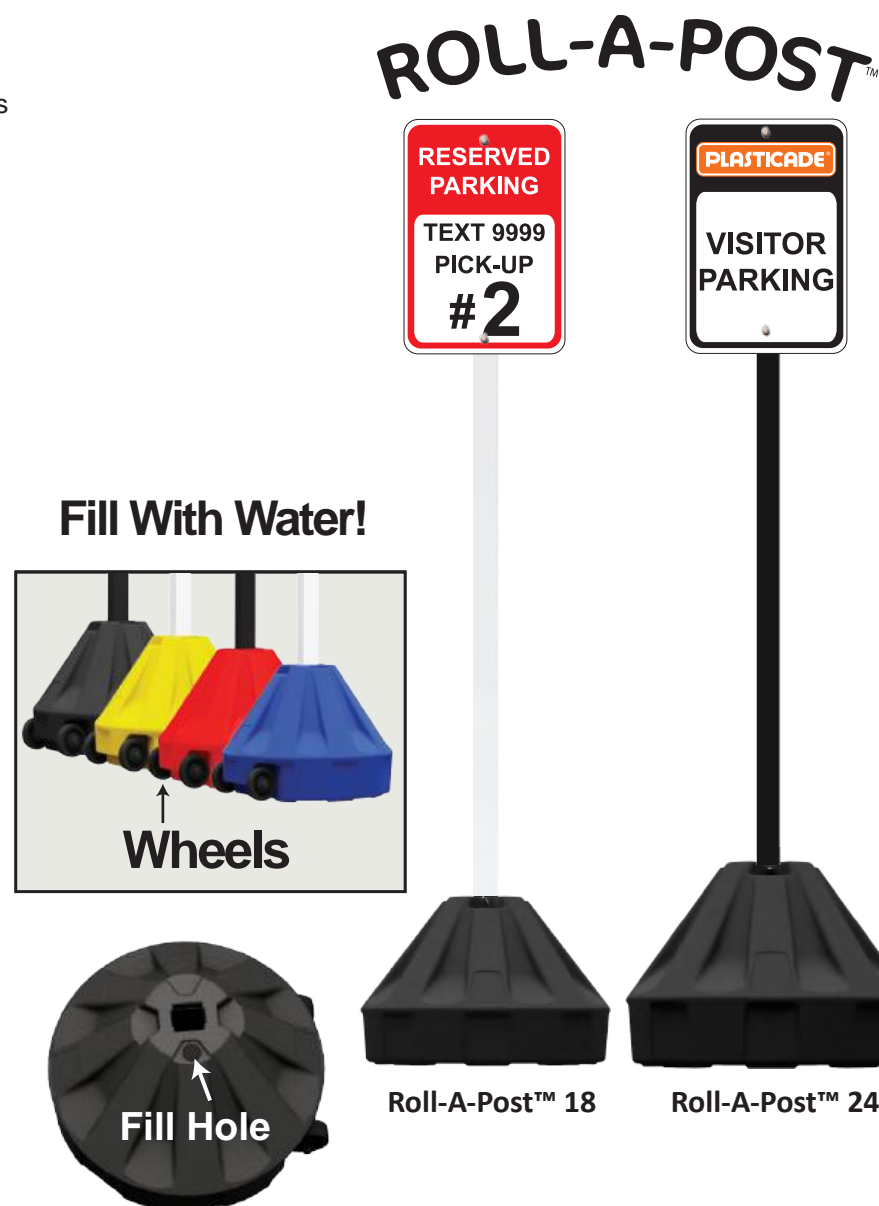

# PARKING LOT SAFETY PRODUCTS

## ROCK-IT™ SIGN STAND

Rock It Back & Roll

### Rock-It™ Plastic Base

Durable, thick walled plastic bases in two sizes, 18" W and 24" W  
- won't chip, crack, or crumble like concrete  
- available in black  
- custom colors with minimum order quantity

Square plastic Power Post™ makes attaching signs easy  
- two lengths: 60"L and 72"L  
- two post colors: white and black  
- lightweight and impact resistant  
- no sign twisting which can occur with round poles  
- will never rust or need painting  
- pre-drilled holes for multiple sign sizes  
- mounting hardware included

Rock it back and roll

- recessed wheels make stands easy to move when weighted  
- sturdy plastic wheels come pre-installed

Withstands strong winds without tipping over when filled with sand

Conveniently placed large fill hole and drain hole  
- fill with dry sand

Lightweight plastic reduces shipping costs

Made in the U.S.A.

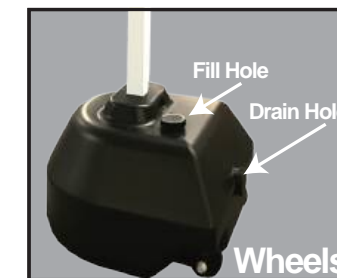

### Rubber Base Portable Post Sign Stands

Durable recycled rubber bases  
- three sizes: 30 lbs., 60 lbs., Stack for 90 lb. base  
- resistant to weather, oil, salt, moisture, & UV light  
- will not warp, chip, or crack

Withstands strong winds without tipping over

Molded-in Hand-grips make bases easy to pick up

Optional wheels makes moving signs even easier  
- heavy duty, non-scratch plastic wheels

Made in the U.S.A.

OPTIONAL WHEELS comes with two double wheel assemblies installed



# PARKING LOT SAFETY PRODUCTS

## Gemstone™ Valet & Parking Lot Signs

High Contrast Reflective Sign Panels Get Noticed!

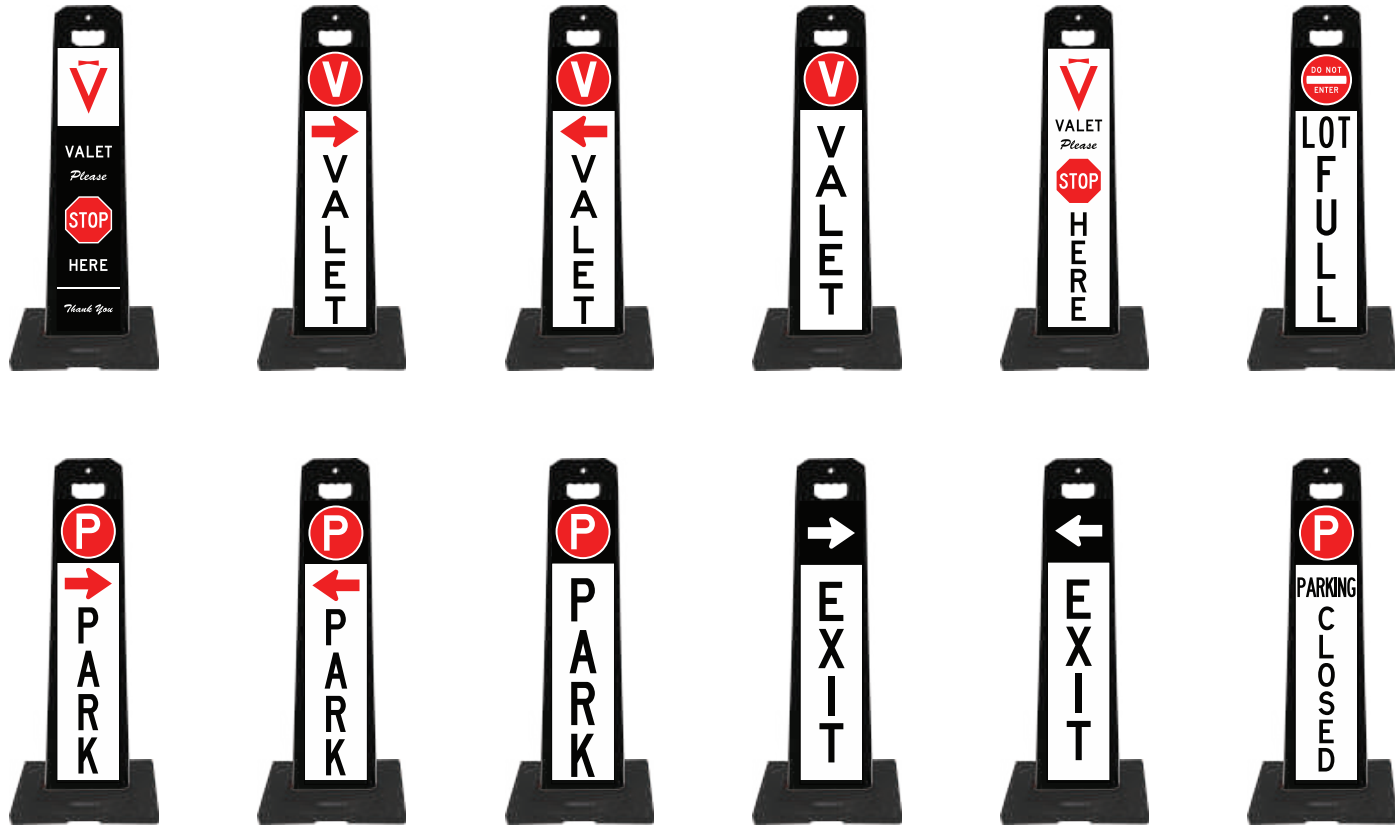

Reflective signs, 36" H x 8" W, applied to black Gemstone™ Vertical Panel  
 - double sided  
 - engineer grade reflective signs  
 - recessed sign surface, reduces damage to signs

Oversized handle with comfort grip  
 - easily pick up sign with base attached

Designed to withstand repeated impacts from vehicles  
 - Gemstone™ sidewall provides strength & durability

Recycled rubber base slides down over sign panel  
 - two sizes, 9 lbs. and 20 lbs.

Stackable with or without rubber base



9 lb. base  
14.5" x 17.5"



20 lb. base  
20" x 20"

# SIGN STANDS - SAFETY SIGNAGE



## ① Choose a Sign Stand

- 6 Sizes
- 3 Colors: white, yellow, or orange

 <p><b>Barricades</b> Hold signs 24"W x 12"H on top panel 4 Types: Plasticade® Fibercade™ Econocade™ Combocade™</p>	 <p><b>Squarecade™ 45</b> Holds signs 24"W x 24"H Dimensions: 45"H x 25"W 18 lbs.</p>	 <p><b>Squarecade™ 36</b> Holds signs 24"W x 24"H Dimensions: 36"H x 25"W 17 lbs.</p>
 <p><b>Narrowcade®</b> Holds signs 12"W x 24"H Dimensions: 45"H x 13"W 11 lbs.</p>	 <p><b>Minicade®</b> Holds signs 12"W x 24"H Dimensions: 36"H x 13"W 10 lbs.</p>	 <p><b>Signicade®</b> Holds signs 24"W x 36"H Dimensions: 45"H x 25"W 18 lbs.</p>

## ② Choose a Sign Legend

- Over 100 Standard Designs
- Custom Design Your Own Sign



## ③ Plasticade will Professionally Apply the Legend to the Sign Stand

- Hassle Free
- Guaranteed Application



### MESSAGE BOARD KIT

Show different messages daily  
 Coroplast™ board comes with tracks permanently attached  
 2 boards per kit  
 Letter set contains over 300 letters and numbers plus "Sale" and "Special" headers  
 Indexed box for letter storage included in kit

Available For: Signicade Deluxe, Signicade, Wind Signs, Econo Classic, & Simpo Sign II





# WHEEL CHOCKS

- Made of 100% post-consumer recycled rubber
- Will not compress, warp, chip, or crack
- UV, oil, and weather resistant



- Can be customized
  - your name or logo embossed in the chock
  - paint for greater visibility and easy identification

## Automotive & Industrial Chocks

Automotive & Industrial Chocks Come Standard With Eye bolt  
Options Available: Painted Chocks or Embossed Name or Logo

**Model 1:** 5.25"W x 6.75"D x 4.5"H, 3.5 lbs. Uses: Autos, Trailers, RVs, Pickups up to 16" Wheels

**Model 2:** 5"W x 9"D x 6"H, 6.5 lbs. Uses: Buses, Paper Rolls

**Model 3:** 10"W x 8"D x 6"H, 8 lbs. Uses: Dump & Tow Trucks, Off Road Vehicles, Utility Trucks, Semi Trucks

**Model 4:** Available as a pair with connecting rope

**Model 5:** Your Name or Logo Embossed, 200 minimum order quantity

**Model 6:** Metal Hairpin Option, painted steel 4" x 1.75"

**Model 7:** Metal Pole Step Handle Option, 7"L galvanized steel

**Model 8:** 9.75"W x 7.75"D x 5"H, 10 lbs. Uses: Utility Vehicles, RVs, Pickups up to 16.5" Wheels

**Model 9:** 10"W x 8"D x 6"H, 11.5 lbs. Uses: Dump & Tow Trucks, Off Road Vehicles, Utility Trucks, Semi Trucks

**Model 10:** 6.75"W x 9.25"D x 8"H, 12 lbs. Uses: Semi Trucks, RVs, Dump & Tow Trucks

**Model 11:** 8.75"W x 8.5"D x 7"H, 15 lbs. Uses: Heavy Equipment, Line Trucks

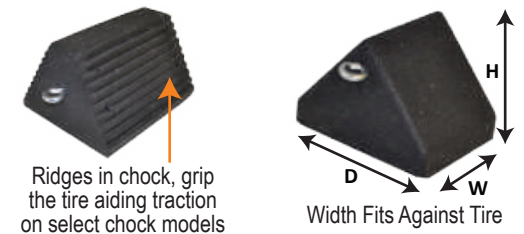

## Aircraft Chocks

**Yellow Rope Connect:** 24"W x 7"D x 5.5"H, 24 lbs. ea. - 48 lbs./pair, Sold in pairs only

**Yellow Rope Handles:** Same dimensions as Yellow Rope Connect

**Vinyl Tubing Over Yellow Rope Handles Option:** Same dimensions as Yellow Rope Connect

Visibility Options		
Cat Eye Reflectors	Painted Recess	Painted Chock
Reflective glass beads help with nighttime visibility. Deep set in recessed area. 4 on each side standard.		
Custom Embossing		
Add your logo, name, website, and/or phone number to both sides of each chock. Standard nameplate size for embossing is 14"W x 3"H		
Name Embossed in Rubber	Name Embossed with Painted Recess	Name Embossed on Painted Chock

Minimum order quantity of 200 required for options



Fibercade™ Barricades on the Eisenhower Expressway - Chicago, IL

Plasticade® was first founded as American Louver® Company in 1954 by Walter Glass. The company began as the inventor and premier manufacturer of plastic parabolic louvers for fluorescent lighting fixtures. Through the years we have used our expertise in plastics manufacturing to expand into many different markets, including Traffic Safety, Sign Frames, Store Fixtures, and Grilles, Registers, and Diffusers for the HVAC market.

At Plasticade® we are committed to manufacturing our products to the highest standards of production. We are continually focusing on improving our procedures, performance, and technologies. Our manufacturing processes include blow molding, injection molding, recycled rubber molding, and extrusion molding. In addition, our staff is dedicated to providing customers with the highest level of customer service.

### Warranty

The Plasticade® family of plastic products have a 30 day limited warranty and rubber products have a 1 year limited warranty. Both cover manufacturer defects only. Damage caused by improper installation, use, or care is the responsibility of the user. This warranty does not include replacement for normal wear and tear. This warranty does not extend to any non-plastic or rubber components that may be part of the products. If a product fails during normal use within the warranty period due to a manufacturer defect, we will replace at no charge.

### US Patents

Many of the products illustrated or described in this catalog are covered by US and foreign patents.

### Disclaimer

Designs are subject to change without prior notice. Any modification or unintended use voids all warranties.

It is the responsibility of the purchaser or user of the product to determine that the product meets the specifications for their unique application and obtain from Plasticade any necessary certifications before use. While Plasticade cannot guarantee that every local or state agency has approved its products, we will provide all available WZ letters, Certificates of Compliance, crash test approvals, QPL and APL approvals for all products.



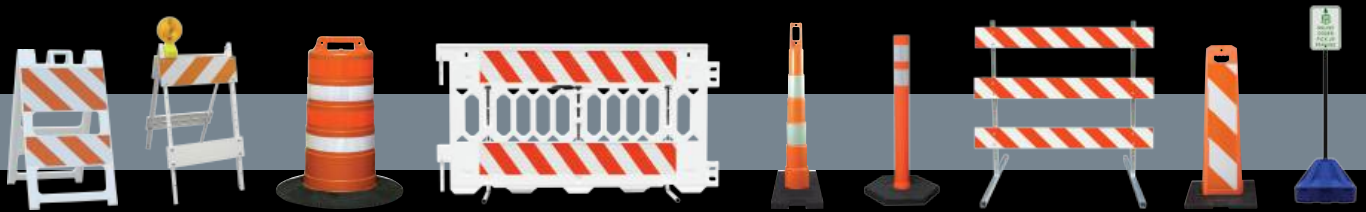

**PLASTICADE®**



**SharpLine Solutions, Inc.**

[www.sharpline-solutions.com](http://www.sharpline-solutions.com) | (626) 257-8328